



User Manual

# EE600

## Differential Pressure Sensor



YOUR PARTNER IN SENSOR TECHNOLOGY



**ELEKTRONIK**<sup>®</sup>  
Ges.m.b.H.

E+E Elektronik Ges.m.b.H. accept warranty and liability claims neither upon this publication nor in case of improper treatment of the described products.

The document may contain technical inaccuracies and typographical errors. The content will be revised and updated on a regular basis. The described products can be improved and changed at any time without prior notice.

© Copyright E+E Elektronik Ges.m.b.H.  
All rights reserved.

**EMC note USA (FCC):**

This equipment has been tested and found to comply with the limits for a Class A digital device, pursuant to part 15 of the FCC Rules. These limits are designed to provide reasonable protection against harmful interference when the equipment is operated in a commercial environment. This equipment generates, uses, and can radiate radio frequency energy and, if not installed and used in accordance with the instruction manual, may cause harmful interference to radio communications. Operation of this equipment in a residential area is likely to cause harmful interference in which case the user will be required to correct the interference at his own expense.

**EMC note Canada (ICES-003):**

CAN ICES-003 (A) / NMB-003 (A)

# CONTENT

<b>1</b>	<b>General</b>	<b>4</b>
1.1	Explanation of Symbols	4
1.2	General Safety Instructions	4
1.2.1	Intended Use	4
1.2.2	Mounting, Start-up and Operation	4
1.3	Environmental Aspects	5
<b>2</b>	<b>Scope of Supply</b>	<b>5</b>
<b>3</b>	<b>Product Description</b>	<b>6</b>
3.1	General	6
3.2	Dimensions	6
3.3	Electrical Connection	7
3.4	User Interface	7
3.4.1	LED Indication	7
3.4.2	Display	7
<b>4</b>	<b>Mounting and Installation</b>	<b>8</b>
4.1	Pressure Connection	8
<b>5</b>	<b>Setup and Configuration</b>	<b>9</b>
5.1	Analogue Version	9
5.1.1	Select the Measuring Range with S1 and S2	10
5.1.2	Select the Response Time with S3 and S4	10
5.1.3	Select the Displayed Unit with S5 and S6	10
5.1.4	Select the Backlight for the Display with S7	10
5.1.5	Select the Output Signal with S8	11
5.1.6	Select the Source of Settings with S9 (Auto-zero Version Only)	11
5.1.7	Outputs	11
5.2	Digital Version	11
5.2.1	RS485 Digital Interface Settings	12
5.2.2	BACnet Protocol Settings	12
5.2.3	Modbus Protocol Settings	12
5.2.4	Modbus Register Map	13
5.2.5	Reading Example	14
5.2.6	Freely Configurable Custom Modbus Map	14
5.2.7	Device Status Indication	15
5.3	Display Settings and Output Signals	15
5.3.1	Analogue Version with DIP Switch Settings	15
5.3.2	Analogue Version with PCS Settings or Digital Version	15
5.4	PCS10 Product Configuration Software	16
5.4.1	Application Settings	17
<b>6</b>	<b>Maintenance and Service</b>	<b>18</b>
6.1	Cleaning	18
6.2	Repairs	18
6.3	Readjustment of EE600	18
6.3.1	Zero Point Adjustment	18
6.3.2	Span Point Adjustment	19
6.3.3	Return to Factory Adjustment	19
6.3.4	Auto-zero (Optional)	19
<b>7</b>	<b>Technical Data</b>	<b>20</b>

# 1 General

This user manual serves for ensuring proper handling and optimal functioning of the device. The user manual shall be read before commissioning the equipment and it shall be provided to all staff involved in transport, installation, operation, maintenance and repair.



**Please find this document and further product information on our website at [www.epluse.com/ee600](http://www.epluse.com/ee600).**

The user manual may not be used for the purposes of competition without the written consent of E+E Elektronik® and may not be forwarded to third parties. Copies may be made for internal purposes. All information, technical data and diagrams included in these instructions are based on the information available at the time of writing.

## Disclaimer

The manufacturer or his authorised agent can only be held liable in case of willful or gross negligence. In any case, the scope of liability is limited to the corresponding amount of the order issued to the manufacturer. The manufacturer assumes no liability for damages incurred due to failure to comply with the applicable regulations, operating instructions or the operating conditions. Consequential damages are excluded from the liability.

## 1.1 Explanation of Symbols



**This symbol indicates safety information.**

It is essential that all safety information is strictly observed. Failure to comply with this information can lead to personal injuries or damage to property. E+E Elektronik® assumes no liability if this happens.



**This symbol indicates instructions.**

The instructions shall be observed in order to reach optimal performance of the device.

## 1.2 General Safety Instructions



- Avoid any unnecessary mechanical stress and inappropriate use.
- Installation, electrical connection, maintenance and commissioning shall be performed by qualified personnel only.
- Use the EE600 only as intended and observe all technical specs.
- Do not blow into the pressure connections.
- Connecting to EE600 a pressure beyond the measurement range according to the product specification may permanently damage the device.
- Do not use EE600 in explosive atmosphere or for measurement of aggressive gases.
- Do not apply the nominal voltage to the output terminals.

### 1.2.1 Intended Use

The EE600 is dedicated for the highly accurate measurement of differential pressure. The multi-range device is suitable for air as well as all non-flammable and non-aggressive gases. The sensor can be used between -20 °C (-4 °F) and +60 °C (+140 °F) and max. 95 %RH (non-condensing).

Please observe the mounting and installation instructions in chapter 4 Mounting and Installation. Check the measuring range for the appropriate use and be aware of the maximum overload limit.

The manufacturer cannot be held responsible for damages as a result of incorrect handling, installation and maintenance of the device.

Unauthorized modifications of the product lead to loss of all warranty claims. The device may only be powered as described in this manual.

### 1.2.2 Mounting, Start-up and Operation

The EE600 differential pressure sensor has been produced under state of the art manufacturing conditions, has been thoroughly tested and has left the factory fulfilling all safety criteria. The manufacturer has taken all precautions to ensure safe operation of the device. The user must ensure that the device is set up and installed in a manner that does not have a negative effect on its safe use.

The user is responsible for observing all applicable safety guidelines, local and international, with respect to safe installation and operation on the device. This operating manual contains information and warnings that must be observed by the user in order to ensure safe operation.

- Mounting, start-up, operation and maintenance of the device may be performed by qualified staff only. Such staff must be authorised by the plant operator to carry out the mentioned activities.
- The qualified staff must have read and understood this operating manual and must follow the instructions contained within.
- All process and electrical connections shall be thoroughly checked by authorised staff before putting the device into operation.
- Do not install or start-up a device supposed to be faulty. Make sure that such devices are not accidentally used by marking them clearly as faulty.
- A faulty device may only be investigated and possibly repaired by qualified, trained and authorised staff. If the fault cannot be fixed, the device shall be removed from the process.
- Service operations other than described in this operating manual may only be performed by the manufacturer.

### 1.3 Environmental Aspects



Products from E+E Elektronik® are developed and manufactured observing of all relevant requirements with respect to environment protection. Please observe local regulations for the device disposal.



For disposal, the individual components of the device must be separated according to local recycling regulations. The electronics shall be disposed of correctly as electronics waste.

## 2 Scope of Supply

- EE600 differential pressure sensor according to ordering guide
- Quick guide
- Test report according to DIN EN 10204-2.2
- Pressure connection set, including 2 m (6.6 ft) PVC hose with two ABS pressure connection nipples
- Mounting material
- For digital version (ordering code J3): one additional M16x1.5 cable gland for daisy chain wiring

# 3 Product Description

## 3.1 General

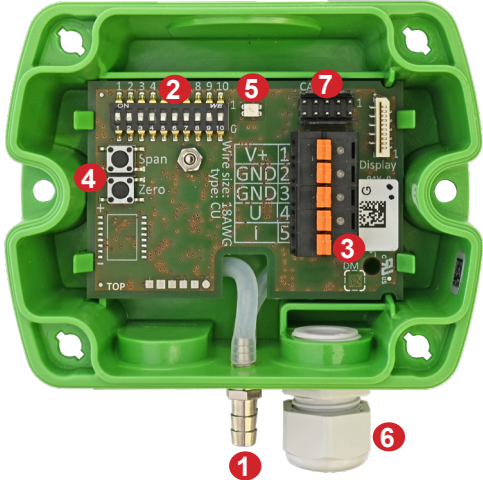
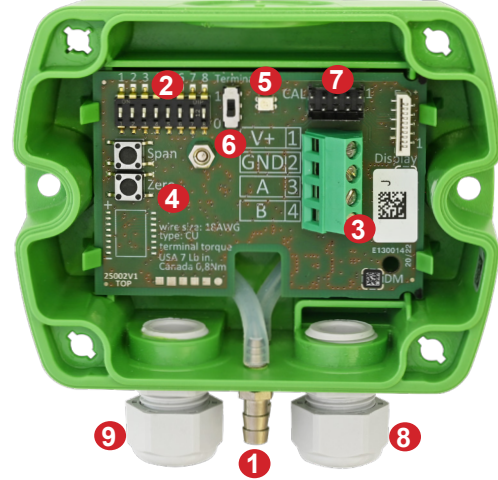
Analogue version (A7)	Digital version (J3)
 <ol style="list-style-type: none"> <li>1. Pressure connection nipples</li> <li>2. DIP switches: Configuration (Ranges, response time, ...)</li> <li>3. Terminals: spring loaded</li> <li>4. Push buttons for zero point and span point adjustment</li> <li>5. Status LED</li> <li>6. Cable gland for wiring</li> <li>7. Service interface connector</li> </ol>	 <ol style="list-style-type: none"> <li>1. Pressure connection nipples</li> <li>2. DIP switches: RS485 addressing</li> <li>3. Terminals: screw</li> <li>4. Push buttons for zero point and span point adjustment</li> <li>5. Status LED</li> <li>6. Slide switch termination resistor</li> <li>7. Service interface connector</li> <li>8. Cable gland for wiring</li> <li>9. Additional cable gland for daisy chain wiring</li> </ol>

Fig. 1 Design and components

## 3.2 Dimensions

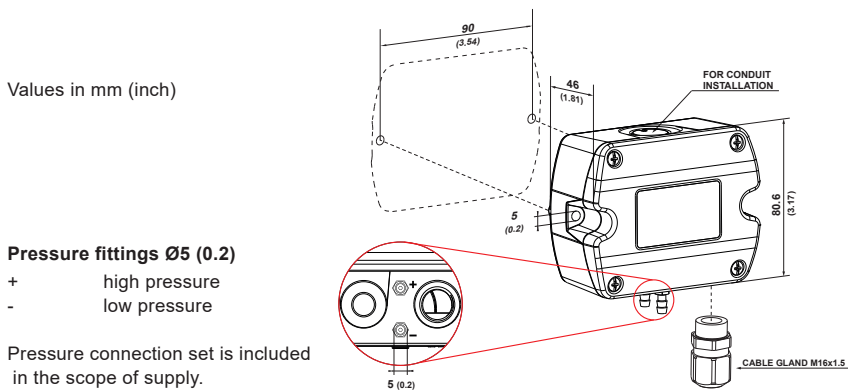



Fig. 2 Dimensions

### 3.3 Electrical Connection

**Important note:**  
 The manufacturer cannot be held responsible for personal injuries or damage to property as a result of incorrect handling, installation, wiring, power supply and maintenance of the device.

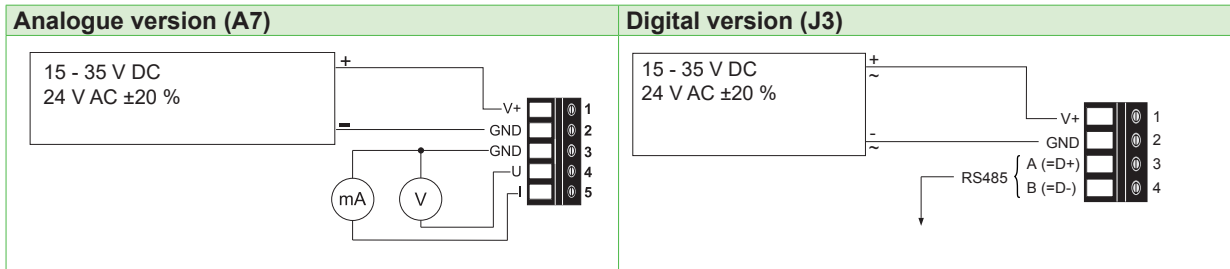


Fig. 3 Connection diagram

### 3.4 User Interface

#### 3.4.1 LED Indication

**Green LED**

- Flashing (1s interval) = EE600 operates normally, the measured data is within the selected measuring range
- One flash (2s) = Confirms adjustment or return to factory settings
- Off = No power supply or electronics failure
- Fast flashing (0.2 s interval) = Auto-zero is executed, first time 10 s after start / reset.

**Red LED**

- Flashing (1s interval) = The measured data is out of the selected range (overload or reversed pressure connection)
- One flash (2s) = Indicates the failure of the attempt to adjust zero point or span point, or to return to factory adjustment

#### 3.4.2 Display

The optional display shows the measured value(s) together with a bar graph or in two lines and has a configurable backlight. It is also indicated when the measured value is out of range.

In the factory setting, the display shows the measured differential pressure in Pascal [Pa]. See chapter 5.3 Display Settings and Output Signals for changing the display settings.



Fig. 4 Display examples

In case of differential pressure out of the measuring range or negative pressure due to inverse pressure connection the display indicates:

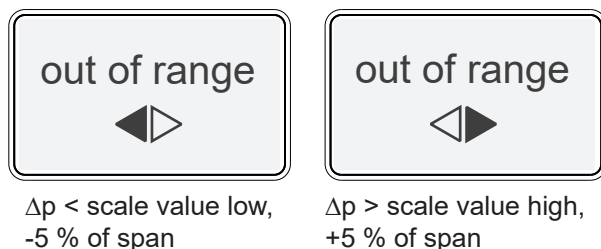


Fig. 5 Out of range indication

## 4 Mounting and Installation



- Mount the EE600 onto a vertical, smooth surface.
- Important: The pressure connection nipples must point downwards.
- Avoid installation close to heaters and sources of strong electromagnetic interference.
- Insert the cable for supply voltage and output signal through the cable gland and connect it to the spring terminals according to the wiring diagram (Fig. 3 Connection diagram).
- Important: Make sure that the connecting cable or wires do not impact with the push buttons in order to prevent unintentional trigger of the span or zero point adjustment.
- Close tightly the cable gland. This is essential for the compliance with the IP65 / NEMA 4X protection rating of the EE600 enclosure.

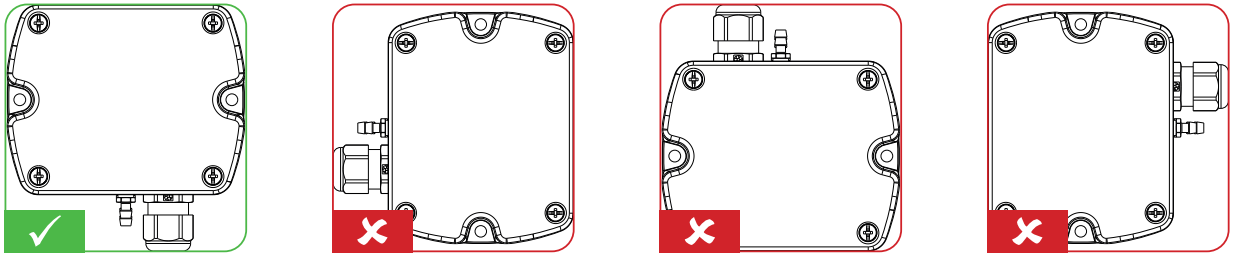


Fig. 6 Mounting orientation

### 4.1 Pressure Connection

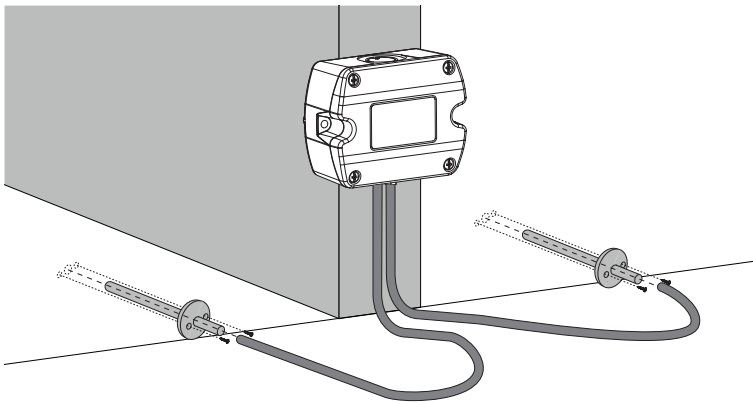


Fig. 7 Pressure connection

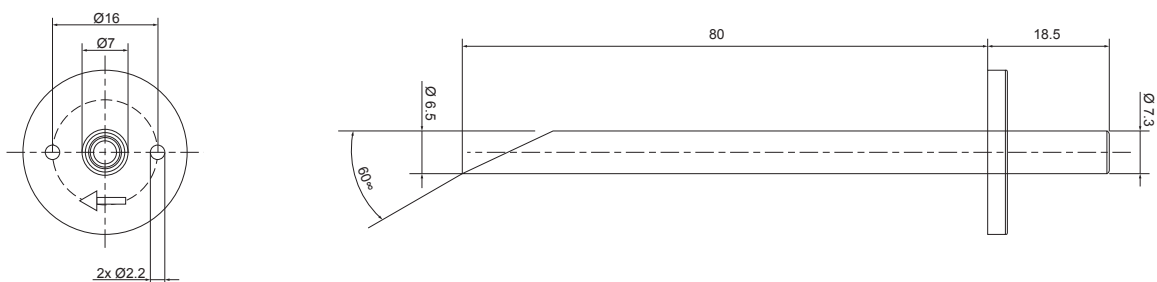


Fig. 8 Dimension of pressure connection nipples

- Install first the pressure connection nipples (included in the scope of supply) onto the duct. Use a  $\text{Ø}7.5$  mm drill.
- Connect the pressure hose (included in the scope of supply) first to the EE600 and then to the nipples at the duct. Route the pressure hose for avoiding sharp bends which might lead to the hose obstruction (Fig. 9 Pressure hose route).



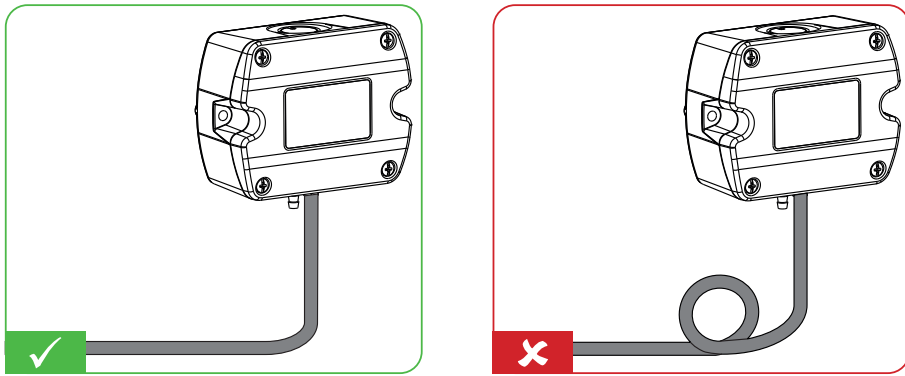


Fig. 9 Pressure hose route



Important: Make sure to connect the higher pressure at the “+” pressure connector and the lower pressure at the “-” pressure connector. Inverted connection leads to “out of range” information on the optional display and at the analogue outputs, see 5.1.7 Outputs and 3.4.2 Display.

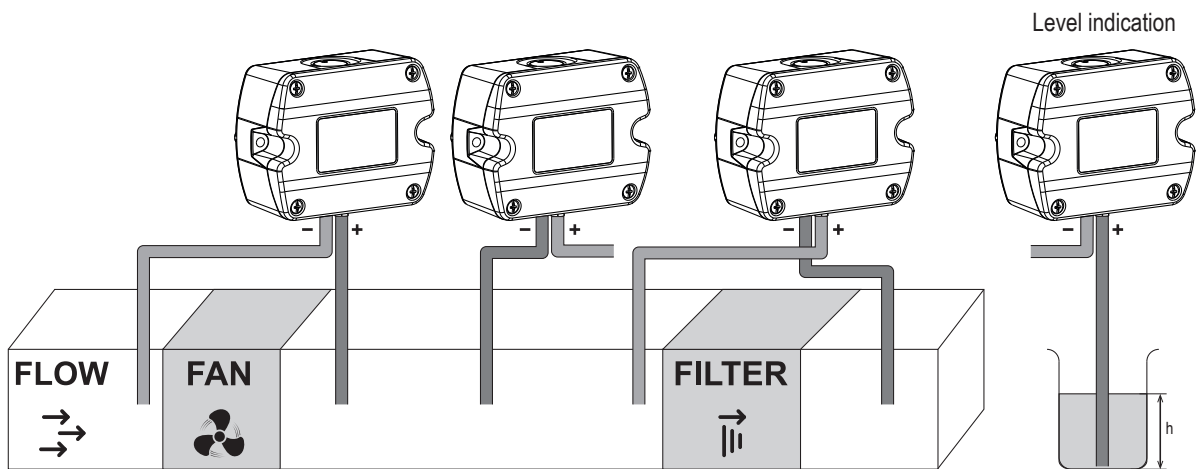


Fig. 10 Mounting examples

## 5 Setup and Configuration

The EE600 is ready to use with its factory settings. The user can change the factory setup with the on-board DIP switches or the PCS10 Product Configuration Software and the USB configuration adapter (order code HA011066), please refer to the chapters below.

### 5.1 Analogue Version

Each EE600 is delivered with the following factory settings (all switches on “0”):

- Measurement range: 100 % of the full scale (1 000 Pa or 10 000 Pa)
- Response time: 50 ms
- Displayed unit: Pa
- Display backlight: on
- Output signals: 0 - 10 V and 4 - 20 mA
- Source of settings: DIP switch settings (only available with auto-zero version)

The analogue version is intended to be configured with the on-board DIP switches. With the auto-zero version, all the changes to the factory setup can also be done with the PCS10.

Settings that can be changed with PCS10:

- Application settings (see chapter 5.4.1 Application Settings)
- Display visualisation (see chapter 5.3.2 Analogue Version with PCS Settings or Digital Version)
- Measurands and their measuring range
- Auto-zero on/off and interval (see chapter 6.3.4 Auto-zero (Optional))
- Response time



EE600 is fully configurable. Before commissioning, set the individual configuration of EE600 according to the application requirements using the DIP switches S1 to S9 as described below (S10 does not have any functionality). The function of the DIP switches is also indicated inside the EE600 front cover.

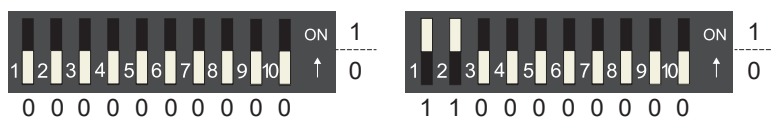


Fig. 11 DIP switch examples



**Please note:** If settings were changed via PCS10 and DIP switch settings shall apply again, be sure to restore the factory settings before applying the DIP switches.

Outputs scale: 0...1000/10.000Pa

Analogue bar limits: -10...1.000/10.000 Pa

Number of lines: 1

### 5.1.1 Select the Measuring Range with S1 and S2

EE600-HV52A7:					
S1	S2	Pa	mbar	inch WC	kPa
0	0	1000	10	4	1
1	0	750	7.5	3	0.75
0	1	500	5	2	0.5
1	1	250	2.5	1	0.25

EE600-HV53A7:					
S1	S2	Pa	mbar	inch WC	kPa
0	0	10000	100	40	10
1	0	7500	75	30	7.5
0	1	5000	50	20	5
1	1	2500	25	10	2.5

Tab. 1 DIP switch settings - Measurement range

### 5.1.2 Select the Response Time with S3 and S4

S3	S4	Response time
0	0	50 ms
1	0	500 ms
0	1	2 s
1	1	4 s

Tab. 2 DIP switch settings - Response time

### 5.1.3 Select the Displayed Unit with S5 and S6

S5	S6	Displayed unit
0	0	Pa
1	0	mbar
0	1	inch WC
1	1	kPa

Tab. 3 DIP switch settings - displayed unit

### 5.1.4 Select the Backlight for the Display with S7

S7	Backlight
0	on
1	off

Tab. 4 DIP switch settings - Backlight

### 5.1.5 Select the Output Signal with S8

EE600 provides simultaneously a voltage and a current output signal at the spring terminals.

S8	Output signals
0	0 - 10 V and 4 - 20 mA
1	0 - 5 V and 0 - 20 mA

Tab. 5 DIP switch settings - Output signals

### 5.1.6 Select the Source of Settings with S9 (Auto-zero Version Only)

S9	Settings Source
0	DIP switches
1	PCS10

Tab. 6 Source of settings

### 5.1.7 Outputs

The measured data is available at the spring terminals as 0 - 10 V and 4 - 20 mA or as 0 - 5 V and 0 - 20 mA signals (see chapter 5.1.5 Select the Output Signal with S8).

Additionally, the analogue outputs indicate measurement out of range as follows.

Indication of  $\Delta p < -5\%$  of measuring range and of negative difference pressure due to inverted pressure connection.

Output signal	Indication of negative differential pressure
0 - 10 V	-0.5 V
0 - 5 V	-0.25 V
4 - 20 mA	3.2 mA
0 - 20 mA	-1 mA

Tab. 7 Indication of  $\Delta p < \text{scale value low, } -5\%$  of span

Indication of  $\Delta p > 105\%$  of measuring range

Output signal	Indication of overload
0 - 10 V	10.5 V
0 - 5 V	5.25 V
4 - 20 mA	20.8 mA
0 - 20 mA	21 mA

Tab. 8 Indication of  $\Delta p > \text{scale value high, } +5\%$  of span

## 5.2 Digital Version

The digital version is intended to be configured with PCS10 Product Configuration Software and the USB configuration adapter (code HA011066). The device address can be overruled by setting the DIP switches (see chapter 5.2.1 RS485 Digital Interface Settings).

Settings that can be changed with the PCS10:

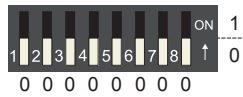
- Digital communication parameters
- Application settings (see chapter 5.4.1 Application Settings)
- Display visualisation (see chapter 5.3.2 Analogue Version with PCS Settings or Digital Version)
- Auto-zero on/off and interval (see chapter 6.3.4 Auto-zero (Optional))
- Response time

## 5.2.1 RS485 Digital Interface Settings

### Hardware Bus Termination

The bus termination can be realised enabling the slide switch on board (120 Ω resistor). Factory setting disabled (see Fig. 1 Design and components, digital version J3).

### Address setting via software



All DIP switches at position 0 → address has to be set via software (via PCS10 Product Configuration Software or via protocol BACnet / Modbus).  
Default address 43.  
*Example: Address is set via Configuration Software.*

### Address setting via DIP switch



Setting the DIP switches to any other address than 0, overrules the default address (43) or the address set via software.  
*Example: Address set to 3 (0000 0011 binary).*

## 5.2.2 BACnet Protocol Settings

	Factory settings	Selectable values
Baud rate	As per type number ordered	9 600, 19 200, 38 400, 57 600, 76 800
Data bits	8	8
Parity	None	None
Stop bits	1	1
Address	43	0...127

Tab. 9 BACnet Protocol settings



The recommended settings for multiple devices in a BACnet MS/TP network are 38 400, 8, None, 1.

The EE600 PICS (Product Implementation Conformance Statement) is available on the website at [www.epluse.com/ee600](http://www.epluse.com/ee600).

BACnet address, baud rate can be set via:

1. PCS10, Product Configuration Software and the USB configuration adapter cable code HA011066
2. BACnet protocol, see the PICS.

## 5.2.3 Modbus Protocol Settings

	Factory settings	Selectable values
Baud rate	As per type number ordered	9 600, 19 200, 38 400
Data bits	8	8
Parity	Even	None, even, odd
Stop bits	1	1 or 2
Address	43	1...247

Tab. 10 Modbus Digital Settings



The recommended settings for multiple devices in a Modbus RTU network are 9 600, 8, Even, 1.

The EE600 represents ½ unit load on an RS485 network.

Modbus address, baud rate, parity and stop bits can be set via:

1. PCS10, Product Configuration Software and the USB configuration adapter HA011066.
2. Modbus protocol in the register 60001 (0x00) and 60002 (0x01). See Application Note Modbus AN0103 (available on [www.epluse.com/ee600](http://www.epluse.com/ee600)).

The measured values are saved as a 32 bit floating point value and as 16 bit signed integer, see the Modbus register map below.

The serial number as ASCII-code is located in the register addresses 0x00...0x07 (16 bits per address).

The firmware version is located in the register address 0x08 (bits 15...8 = major release; bits 7...0 = minor release). The sensor name is located in register address 0x09. The beforementioned registers can be read out with function code 0x03 or 0x04.



**Please note:** When reading the serial number or the sensor name, it is always necessary to read all 8 registers, even if the desired information requires less.



**Please note:** For obtaining the correct floating point values, both registers have to be read within the same reading cycle. The measured value can change between two Modbus requests, therefore, exponent and mantissa may get inconsistent.

Communication settings (INT16)		
Parameter	Register number <sup>1)</sup> [Dec]	Protocol address <sup>2)</sup> [Hex]
<b>Write register: function code 0x06</b>		
Modbus address	1	0x00
Modbus protocol settings <sup>3)</sup>	2	0x01
Initiate manual zeroing	508	1FB

Device information (INT16)		
Parameter	Register number <sup>1)</sup> [Dec]	Protocol address <sup>2)</sup> [Hex]
<b>Read register: function code 0x03 / 0x04</b>		
Serial number (as ASCII)	1	0x00
Firmware version	9	0x08
Sensor Name	10	0x09
Device status (bit decoded) <sup>4)</sup>	602	0x259

1) Register number starts from 1.

2) Protocol address starts from 0.

3) For Modbus protocol settings see Application Note Modbus AN0103 (available at [www.epluse.com/ee600](http://www.epluse.com/ee600)).

4) See chapter 5.2.7 Device Status Indication.

## 5.2.4 Modbus Register Map

FLOAT32			
Measured value	Unit	Register number <sup>1)</sup> [Dec]	Protocol Address <sup>2)</sup> [Hex]
<b>Read register: function code 0x03 / 0x04</b>			
Differential pressure	mm H <sub>2</sub> O	1211	0x4BA
Differential pressure	mbar	1213	0x4BC
Differential pressure	Pa	1215	0x4BE
Differential pressure	kPa	1217	0x4C0
Differential pressure	inch WC	1219	0x4C2
Air velocity	m/s	1041	0x410
Air velocity	ft/min	1043	0x412
Volume flow	m <sup>3</sup> /h	1055	0x41E
Volume flow	l/s	1057	0x420
Volume flow	m <sup>3</sup> /s	1059	0x422
Volume flow	ft <sup>3</sup> /min	1181	0x49C
Filter monitoring	%	1075	0x432
Level indicator	cm	1077	0x434
Level indicator	inch	1079	0x436

INT16				
Measured value	Unit	Scale <sup>3)</sup>	Register number <sup>1)</sup> [Dec]	Protocol Address <sup>2)</sup> [Hex]
<b>Read register: function code 0x03 / 0x04</b>				
Differential pressure	mm H <sub>2</sub> O	10	4106	0x1009
Differential pressure	mbar	100	4107	0x100A
Differential pressure	Pa	1	4108	0x100B
Differential pressure	kPa	1000	4109	0x100C
Differential pressure	inch WC	100	4110	0x100D
Air velocity	m/s	100	4021	0xFB4
Air velocity	ft/min	1	4022	0xFB5
Volume flow	m <sup>3</sup> /h	1	4028	0xFBB
Volume flow	l/s	1	4029	0xFBC
Volume flow	m <sup>3</sup> /s	1000	4030	0xFBD
Volume flow	ft <sup>3</sup> /min	1	4091	0xFFA
Filter monitoring	%	10	4038	0xFC5
Level indicator	cm	10	4039	0xFC6
Level indicator	inch	10	4040	0xFC7

INT16		
Parameter name	Register number <sup>1)</sup> [Dec]	Register address <sup>2)</sup> [Hex]
Write register: function code 0x06		
Modbus address <sup>4)</sup>	0001	0x00
Modbus protocol settings <sup>5)</sup>	0002	0x01
Initiate manual zeroing	508	1FB

<sup>1)</sup> Register number starts from 1

<sup>2)</sup> Register address starts from 0

<sup>3)</sup> 100 is scale 1:100 (2550 is equivalent to 25.50)

<sup>4)</sup> If the Address is set via DIP switches, the response will be NAK

<sup>5)</sup> For Modbus protocol settings please see Application Note Modbus AN0103 (available on [www.epluse.com/ee600](http://www.epluse.com/ee600)).

INFO (read register)		
Parameter name	Register number <sup>1)</sup> [Dec]	Register address <sup>2)</sup> [Hex]
Read register: function code 0x03 / 0x04		
Serial number (as ASCII)	0001	0x00
Firmware version	0009	0x08
Sensor Name	0010	0x09
Status / Error information	0602	0x259

## 5.2.5 Reading Example

Example of Modbus RTU command for reading the differential pressure (float value)  $\Delta p = 497,965972$  Pa from the register 0x4BE:

Device EE600; Address 43 [0x2B]

Reference document, chapter 6.3: [www.modbus.org/docs/Modbus\\_Application\\_Protocol\\_V1\\_1b.pdf](http://www.modbus.org/docs/Modbus_Application_Protocol_V1_1b.pdf)

Request [Hex]: 2B 04 04 BE 00 02 17 15

	Modbus address	Function code	Starting address Hi	Starting address Lo	No. of register Hi	No. of register Lo	CRC	
Request [Hex]:	2B	04	04	BE	00	02	17	15

Response [Hex]: 2B 04 04 FB A5 43 F8 61 F3

	Modbus address	Function code	Byte count	Register 1 value Hi	Register 1 value Lo	Register 2 value Hi	Register 2 value Lo	CRC	
Response [Hex]:	2B	04	04	FB	A5	43	F8	61	F3

For decoding of float values (stored according standard IEEE754), please refer to AN0103, chapter 7 (available on [www.epluse.com/ee600](http://www.epluse.com/ee600)).

## Example of decoding

Response [Hex]				Decimal value
Byte 1 (Register 2 - Hi)	Byte 2 (Register 2 - Lo)	Byte 3 (Register 1 - Hi)	Byte 4 (Register 1 - Lo)	
43	F8	FB	A5	497,965972

## 5.2.6 Freely Configurable Custom Modbus Map

It is possible to map measured value/status registers arbitrarily in a block with up to 20 registers provided for this purpose. This means that registers of interest may be mapped in an area with consecutive registers, so that important values can be queried with a single command in one block.

The custom map can be configured via:

1. PCS10 Product Configuration Software and the USB configuration adapter HA011066.

The PCS10 can be downloaded free of charge from [www.epluse.com/pcs10](http://www.epluse.com/pcs10).

2. Modbus protocol commands, refer to the example in chapter 5.6 Modbus RTU Examples.

The register block for the configuration of the customisable Modbus map consists of the registers 6001 (0x1770) to 6010 (0x1779). For the blockwise query of the measured values behind Modbus registers 3001 (0xBB8) to 3020 (0xBCB), the firmware accesses this configuration area and thus gets the information which measured value/status registers are to be output. A maximum of 10 user-defined registers can be mapped. The table below shows an example:

Registers ...		... with these assigned measurands ...			... map to registers ...		... mirrored from source registers	
Dec	Hex	Meas.	Unit	Type	Dec <sup>1)</sup>	Hex <sup>2)</sup>	Dec <sup>1)</sup>	Hex <sup>2)</sup>
<b>Function code 0x10</b>				<b>Function code 0x03 / 0x04</b>				
6001	0x1770	ΔP	Pa	INT16	3001	0xBB8	4108	0x100B
6002	0x1771	V'	m <sup>3</sup> /h	FLOAT32	3002	0xBB9	1055	0x41E
				FLOAT32	3003	0xBBA	1056	0x41F
6003	0x1772	v	m/s	FLOAT32	3004	0xBBB	1041	0x410
				FLOAT32	3005	0xBBC	1042	0x411

1) Register number starts from 1.

2) Protocol address starts from 0.

Tab. 11 Custom Modbus map example

### 5.2.7 Device Status Indication

If a critical error occurs, all Modbus values are set to NaN (according to IEEE754 for data type FLOAT32) or to 0x8000 (INT16). It is possible to read out all status and error information via Modbus register 602 (0x259). Errors are displayed in bit-coded form. If an event is present, the corresponding bit is set to 1.

Measured values outside the measuring range are limited with the corresponding limit value.

Error Bits	Description	Recommended action
Bit 0	Error: Sensor not adjusted	1. Carry out zero point adjustment 2. Return to factory adjustment 2. Return the faulty unit to E+E for service
Bit 1	Error: Pressure measurement faulty	1. Check the installation and clean the device 2. Carry out zero point adjustment 3. Return the faulty unit to E+E for service
Bit 2	Error: Faulty display communication	1. Check the display connection
Bit 3	Error: Auto-zero did not work	1. Carry out zero point adjustment 2. Return the faulty unit to E+E for service
The remaining bits are not relevant		

Tab. 12 Device status indication register

## 5.3 Display Settings and Output Signals

### 5.3.1 Analogue Version with DIP Switch Settings

See chapter 5.1 Analogue Version for the configuration options.

### 5.3.2 Analogue Version with PCS Settings or Digital Version

The factory setting of the display (if present) shows the measured differential pressure in Pascal [Pa]. All measurands can also be selected as output signal. With the PCS10 Product Configuration Software and the optional USB configuration adapter HA011066, the user can change the display layout, the visualised parameter according to the selected application and the output signal:

#### Differential pressure measurement

Unit: Pa, kPa, mbar, mm H<sub>2</sub>O, inch WC,  
Layout: one line with limit bar

#### Volume flow measurement

Unit: m<sup>3</sup>/h, m<sup>3</sup>/s, ft<sup>3</sup>/min, l/s  
Layout: one line with limit bar or two lines (volume flow and differential pressure) without limit bar.

#### Air velocity measurement

Unit: m/s, ft/min  
Layout: one line with limit bar or two lines (air velocity and differential pressure) without limit bar.

## Filter monitoring

Unit: %

Layout: one line with limit bar or two lines (filter monitoring and differential pressure) without limit bar.

## Level indicator

Unit: cm, inch

Layout: one line with limit bar or two lines (level indicator and differential pressure) without limit bar.

## Examples of display visualisation



Fig. 12 Display with one line with limit bar and two lines without limit bar



**Please note:** If settings were changed via PCS10 and DIP switch settings shall apply again, be sure to restore the factory settings before applying the DIP switches.

Outputs scale: 0...1000/10.000Pa

Analogue bar limits: -10...1.000/10.000 Pa

Number of lines: 1

## 5.4 PCS10 Product Configuration Software



Only available with analogue version with auto-zero and digital version.

For performing adjustment or changes in EE600 settings, please proceed as follows:

1. Download the PCS10 Product Configuration Software from [www.epluse.com/pcs10](http://www.epluse.com/pcs10) and install it on the PC.
2. Connect the EE600 to the PC using the USB configuration adapter.
3. Start the PCS10 software.
4. Follow the instructions on the PCS10 opening page for scanning the ports and identifying the connected device.
5. Click on the desired setup or adjustment mode from the main PCS10 menu on the left and follow the online instructions of the PCS10
6. Refer to the tutorial available throughout PCS10.

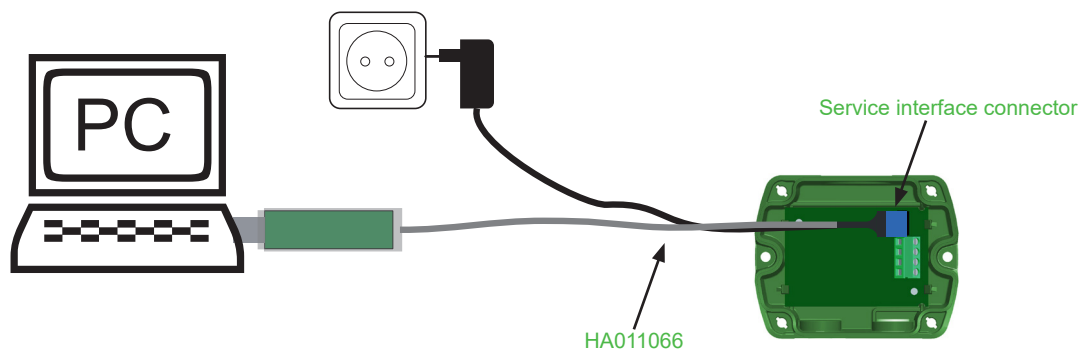


Fig. 13 EE600 configuration and adjustment



**Please note:** The EE600 may not be connected to any additional power supply when using the USB configuration adapter HA011066.



### 5.4.1 Application Settings

This chapter gives some details concerning the possible applications and their inputs.

Beside differential pressure measurement (Pa, kPa, mbar, mm H<sub>2</sub>O, inch WC), the EE600 can be set up for the following applications:

- Volume flow rate measurement (k-factor input)
- Air velocity measurement (k-factor input)
- Filter monitoring
- Level indication

#### Volume flow measurement

By entering a k-factor under application settings, the EE600 is able to calculate the volume flow (q) according to the formula:

$$q = k * \sqrt{\Delta p}$$

q = volume flow [m<sup>3</sup>/h]  
 Δp = differential pressure [Pa]  
 k = k-factor

The k-factor is a characteristic theoretical parameter for each fan model, specified by the manufacturer in the datasheet of the fan.



**Please note:** If the data sheet of the fan manufacturer specifies a different method or unit of calculating the volume flow, the k-factor must be converted accordingly to fit the above formula.

Example: If the k-factor (k<sub>specific</sub>) in the data sheet of the fan manufacturer applies for volume flow calculation in m<sup>3</sup>/s it has to be converted as follows:

$$q[\text{m}^3/\text{s}] = k_{\text{specific}} * \sqrt{\Delta p} \quad kE + E = k_{\text{specific}} * 3600$$

The calculated volume flow (q) is available in four different units: m<sup>3</sup>/h, m<sup>3</sup>/s, ft<sup>3</sup>/min, l/s.

The default air density (ρ<sub>20</sub>) value at standard conditions is defined as follows:

Air density (ρ<sub>20</sub>): 1,204 kg/m<sup>3</sup> @: T = 20 °C (68 °F), p = 1 013 mbar (14,7 psi)

If the air density deviates from standard conditions, a compensation for the calculated volume flow is necessary.

By entering the specific air density (ρ') [kg/m<sup>3</sup>] at the operating point, the EE600 applies a compensation to the calculated volume flow (q') according to the formula:

$$q' = k * \sqrt{\Delta p} * \sqrt{\frac{\rho_{20}}{\rho'}}$$

q' = volume flow at specific density [m<sup>3</sup>/h]  
 Δp = differential pressure [Pa]  
 k = k-factor  
 ρ' = specific air density [kg/m<sup>3</sup>]  
 ρ<sub>20</sub> = air density at 20 °C (68 °F) [kg/m<sup>3</sup>]

#### Air velocity measurement

By entering a k-factor and the dimensions of the duct (round or square), the EE600 is able to calculate the air velocity (v) out of the volume flow (q) and the area of the duct.

$$v = \frac{q/3600}{A}$$

v = air velocity [m/s]  
 q = volume flow [m<sup>3</sup>/h]  
 A = Area [m<sup>2</sup>]

Details for k-factor see application settings for volume flow measurement.

The calculated air velocity (v) is available in two different units: m/s and ft/min.

Details for setting air density (when deviating from default air density at standard conditions) see application settings for volume flow measurement.

## Filter monitoring

By entering filter limits for differential pressure, the EE600 is able to calculate a contamination level for the observed filter in order to plan for maintenance purposes.

For the given application setting ( $\Delta p$  change filter = 800 Pa,  $\Delta p$  new filter = 100 Pa) a measured differential pressure at the filter of  $\Delta p = 450$  Pa, would mean a contamination level of 50 %:

$$\text{contamination level [\%]} = \frac{\text{measured } \Delta p - \Delta p \text{ new filter}}{\Delta p \text{ change filter} - \Delta p \text{ new filter}}$$

The filter contamination level is available expressed in percentage [%].

## Level indicator

By entering the density [ $\text{kg/m}^3$ ] of a fluid the EE600 can act as a level indicator. The differential pressure level measurement uses the pressure values and the specific weight of the fluid to represent the level in a tank (see Fig. 10 Mounting examples).

$$h = \frac{\Delta p}{\rho * g} * 100$$

$h$  = Level (cm)  
 $\Delta p$  = Differential pressure (Pa)  
 $\rho$  = Density of fluid ( $\text{kg/m}^3$ )  
 $g$  = Gravitational acceleration ( $9,81 \text{ m/s}^2$ )

By applying the positive pressure connection into the tank, the user can measure the height of the column of that fluid.

The level measurement is available in two different units: cm and inch.

The maximum measurable level is limited by the highest differential pressure range 0...10 000 Pa.

For example, for water with density  $998 \text{ kg/m}^3$ , at 10 000 Pa the maximum height is 102 cm (40 inch).

# 6 Maintenance and Service

EE600 does not require any special maintenance, nevertheless it is recommended to perform a zero point adjustment every 12 month. If needed, the enclosure may be cleaned and the device may be re-adjusted as described below.

## 6.1 Cleaning

Use a damp soft cloth to remove deposits of dust or dirt from the exterior of the device and from the display. Do not attempt to clean the interior of the device. Do not use any solvents, alcohol or abrasive cleaning agents.

## 6.2 Repairs

Repairs may be carried out by the manufacturer only. The attempt of unauthorised repair excludes any warranty claims.

## 6.3 Readjustment of EE600

A periodical readjustment of EE600 might be required by the regulations of certain industries or by the need of best long-term measurement accuracy. The zero point and the span point can be adjusted with push buttons on the EE600 electronics board.

For adjustment the device must be powered and the enclosure cover removed. Consequently, the adjustment may be performed by authorised staff only, observing the handling of electrical sensitive devices (ESD).

### 6.3.1 Zero Point Adjustment

The zero point adjustment is used to correct an eventual zero point deviation.

- Remove the tubes from both pressure connections of the EE600. By this the pressure equal on both connections. If the sensor has an auto-zero setting, the tubes do not need to be removed.
- Press "zero point" button 1-2 sec. (see 3 Product Description).
- The successful zero point adjustment is confirmed by the green LED turning on for 2 seconds.

- d. The red LED turning on for 2 seconds indicates that the zero point adjustment did not succeed. In this case repeat b.
- e. The zero point adjustment (b.) may not succeed because of a deviation higher than 5 % of the original full scale of the device. This is 50 Pa for the 0...1 000 Pa range and 500 Pa from the 0...10 000 Pa range. If the zero point adjustment is not successful even after pressing the button for at least 10 seconds, then the deviation is too high for zeroing. Please check the sensor, the tubes and the environment and make sure that the pressure connection nipples are free.
- f. The successful zero point adjustment is confirmed by the green LED turning on for 2 seconds.

### 6.3.2 Span Point Adjustment

The span point adjustment is used to correct an eventual deviation of the span value.



Important:

Make sure to perform a zero point adjustment as above before any span point adjustment.

- a. Connect the differential pressure reference device/calibrator to the EE600 and set it according to the EE600 span value to be adjusted.
- b. Note: The span value has to be set according to the selected measurement range.

Example:

Analogue version: (see 5.1.1 Select the Measuring Range with S1 and S2, Tab. 1)  
EE600-HV53A7, S1 = 0, S2 = 1, span value = 5 000 Pa

Digital version: EE600-HV52J3, span value = 1 000 Pa  
EE600-HV53J3, span value = 10 000 Pa



Observe the operation manual of the reference device.

- c. Press the span point adjustment button (see 3 Product Description).
- d. The successful span point adjustment is confirmed by the green LED turning on for 2 seconds.
- e. The red LED turning on for 2 seconds indicate that the span point adjustment did not succeed. In this case repeat b.
- f. The span point adjustment (b.) may not succeed because of a deviation higher than 5 % of the original full scale of the device.  
This is 50 Pa for the 0 – 1 000 Pa range and 500 Pa from the 0...10 000 Pa range. In this case, the set point adjustment can be forced by pressing and holding the span point button for 10 sec.
- g. The successful span point adjustment is confirmed by the green LED turning on for 2 seconds.

### 6.3.3 Return to Factory Adjustment

- a. Press and hold simultaneously both “zero” and “span” buttons for 5 sec.
- b. The successful return to factory adjustment is confirmed by the green LED turning on for 2 seconds.
- c. The red LED turning on for 2 seconds indicates that the return to factory adjustment did not succeed. In this case repeat b.



Important:

Return to factory adjustment affects both zero and span.

### 6.3.4 Auto-zero (Optional)

With auto-zero, no maintenance of the sensor is necessary. Auto-zero is carried out every 24 hours (factory setting). Changing the interval is possible with PCS 10 and the USB configuration adapter (see chapter 5.4 PCS10 Product Configuration Software). The interval can be set from 10 minutes up to 7 days. For this purpose DIP switch 9 (see chapter 5.1.6 Select the Source of Settings with S9 (Auto-zero Version Only)) has to be in position 1 (ON). During the auto-zero procedure (takes approx. 4 s), the green LED flashes quickly (see chapter 3.4.1 LED Indication) and the most recent measured value is frozen.



**Please note:** If the auto-zero interval was changed via PCS10 and DIP switch settings are applied again, the auto-zero interval value will be adopted.

# 7 Technical Data

## Measurands

### Differential Pressure ( $\Delta p$ )

<b>Measurement principle</b>	Piezoresistive, no flow-through	
<b>Measuring range</b> <b>Analogue output selectable with DIP switches<sup>1)</sup></b>	0...250/500/750/1 000 Pa 0...2500/5000/7500/10 000 Pa	
<b>With PCS10</b>	Configurable within max. measuring range	
<b>Accuracy</b> @ 20 °C (68 °F), incl. hysteresis, non-linearity and repeatability	±0.5 % FS	FS = full scale (1 000 Pa or 10 000 Pa)
<b>Temperature dependency, typ.</b>	<0.03 % from FS/K	
<b>Response time <math>t_{90}</math></b>	<b>Analogue output<sup>1)</sup></b>	50 ms/500 ms/2 s/4 s selectable with DIP switches Configurable in the range from 0.05 to 30 s with PCS10
	<b>Digital interface<sup>2)</sup></b>	Configurable in the range from 0.5 to 30 s with PCS10
<b>Auto-zero interval</b>	24 h (factory setting) Configurable between 10 min and 7 days with PCS10. Can be deactivated.	
<b>Long-term stability</b>	<0.5 % FS/year	
<b>Overload limits</b>	<b>1 000 Pa FS</b>	±10 000 Pa
<b>10 000 Pa FS</b>		±80 000 Pa

1) Factory setup analogue output: measurement range 0...100 % FS; response time  $t_{90}$ : 50 ms; displayed unit: Pa; display backlight: on; analogue outputs: 0 - 10 V and 4 - 20 mA. Other ranges upon request.

2) Factory setup RS485: response time  $t_{90}$ : 500 ms; displayed unit: Pa; display backlight: on

### Calculated measurands

		Unit
<b>Level Indicator</b>	LI	cm
		inch
<b>Volume flow</b>	V'	m <sup>3</sup> /h
		l/s
		m <sup>3</sup> /s
		ft <sup>3</sup> /min
<b>Air velocity</b>	v	m/s
		ft/min
<b>Filter contamination level</b>	FCL	%

## Configurability

Device	DIP switches	PCS10
Analogue output without auto-zero	✓	
Analogue output with auto-zero	✓	✓
Digital interface without auto-zero	✓	✓
Digital interface with auto-zero	✓	✓

Configuration options see above or manual at [www.epluse.com/ee600](http://www.epluse.com/ee600).

## Outputs

### Analogue




<b>Analogue output<sup>1)</sup></b>	0 - 5 V or 0 - 10 V and 0 - 20 mA or 4 - 20 mA (3-wire)	-1 mA < I <sub>L</sub> < 1 mA  R <sub>L</sub> ≤ 500 Ω	I <sub>L</sub> = load current  R <sub>L</sub> = load resistor
-------------------------------------	---	---	---

1) Voltage and current output signals available simultaneously at the spring loaded terminals. Settings selectable with DIP switches.  
Factory setup analogue outputs: measurement range 0...100 % FS; response time t<sub>90</sub>: 50 ms; displayed unit: Pa; display backlight: on; analogue outputs: 0 - 10 V and 4 - 20 mA. Other ranges upon request.

### Digital

<b>Digital interface</b>	RS485 (EE600 = 1/2 unit load)
<b>Protocol</b> <b>Factory settings</b> <b>Supported Baud rates</b> <b>Data types for measuring values</b>	Modbus RTU Baud rate see order information, parity even, 1 stop bit, Modbus address 43 9 600, 19 200 and 38 400 FLOAT32 and INT16
<b>Protocol</b> <b>Factory settings</b> <b>Supported Baud rates</b>	BACnet MS/TP Baud rate see order information, BACnet address 43 9 600, 19 200, 38 400, 57 600 and 76 800

## General

<b>Power supply</b> class III  USA & Canada: Class 2 supply necessary, max. voltage 30 V DC	15 - 35 V DC or 24 V AC ±20 %		
<b>Current consumption, typ.</b> @ 0 Pa (0 psi)/24 V DC		<b>Analogue output</b>	<b>Digital interface</b>
	<b>Without display</b>	23 mA	8 mA
	<b>Display with backlight</b>	49 mA	29 mA
<b>Electrical connection</b>	<b>Analogue output</b> <b>Digital interface</b>	Spring-loaded terminals, max. 1.5 mm <sup>2</sup> (AWG16) Screw terminals, max. 2.5 mm <sup>2</sup> (AWG14)	
<b>Cable gland</b>	M16x1.5		
<b>Display</b>	Graphic, with backlight		
<b>Selectable units on display with</b> <b>Analogue output via DIP switch</b> <b>Analogue output and digital interface via PCS10</b>	Pa, kPa, mbar, mm H <sub>2</sub> O Pa, kPa, mbar, mm H <sub>2</sub> O, inch WC, m <sup>3</sup> /h, m <sup>3</sup> /s, ft <sup>3</sup> /min, l/s m/s, ft/min, %		
<b>Humidity range</b>	0...95 %RH, non-condensing		
<b>Temperature range</b>	<b>Operation</b> <b>Storage</b>	-20...+60 °C (-4...+140 °F) -40...+70 °C (-40...+158 °F)	
<b>Enclosure</b>	<b>Material</b> <b>Protection rating</b>	Polycarbonate, UL94 V-0 (with display UL94 HB) approved IP65/NEMA 4X	
<b>Electromagnetic compatibility</b>	EN 61326-1 FCC Part15 Class A	EN 61326-2-3 ICES-003 Class A	Industrial environment
<b>Shock and vibration</b>	Tested according to EN 60068-2-64 and EN 60068-2-27		
<b>Conformity</b>	 		



#### HEADQUARTERS

##### **E+E Elektronik Ges.m.b.H.**

Langwiesen 7  
4209 Engerwitzdorf  
Austria  
Tel.: +43 7235 605-0  
E-mail: [info@epluse.com](mailto:info@epluse.com)  
Web: [www.epluse.com](http://www.epluse.com)

#### SUBSIDIARIES

##### **E+E Elektronik China**

18F, Kaidi Financial Building,  
No.1088 XiangYin Road  
200433 Shanghai  
Tel.: +86 21 6117 6129  
E-mail: [info@epluse.cn](mailto:info@epluse.cn)

##### **E+E Elektronik France**

47 Avenue de l'Europe  
92310 Sèvres  
Tel.: +33 4 74 72 35 82  
E-mail: [info@epluse.fr](mailto:info@epluse.fr)

##### **E+E Elektronik Germany**

Obere Zeil 2  
61440 Oberursel  
Tel.: +49 6171 69411-0  
E-mail: [info@epluse.de](mailto:info@epluse.de)

##### **E+E Elektronik India**

801, Sakhi Vihar Road  
400072 Mumbai  
Tel.: +91 990 440 5400  
E-mail: [info.in@epluse.com](mailto:info.in@epluse.com)

##### **E+E Elektronik Italy**

Via Alghero 17/19  
20128 Milano (MI)  
Tel.: +39 02 2707 86 36  
E-mail: [info@epluse.it](mailto:info@epluse.it)

##### **E+E Elektronik Korea**

Suite 2001, Heungdeok IT  
Valley Towerdong, 13,  
Heungdeok 1-ro, Giheung-gu  
16954 Yongin-si, Gyeonggi-do  
Tel.: +82 31 732 6050  
E-mail: [info@epluse.co.kr](mailto:info@epluse.co.kr)

##### **E+E Elektronik USA**

333 East State Parkway  
Schaumburg, IL 60173  
Tel.: +1 847 490 0520  
E-mail: [office@epluse.com](mailto:office@epluse.com)